

Please write clearly in block capitals.

Centre number

--	--	--	--	--

Candidate number

--	--	--	--

Surname

Forename(s)

Candidate signature

I declare this is my own work.

A-level PHYSICS

Paper 2

Time allowed: 2 hours

Materials

For this paper you must have:

- a pencil and a ruler
- a scientific calculator
- a Data and Formulae Booklet
- a protractor.

Instructions

- Use black ink or black ball-point pen.
- Fill in the boxes at the top of this page.
- Answer **all** questions.
- You must answer the questions in the spaces provided. Do not write outside the box around each page or on blank pages.
- If you need extra space for your answer(s), use the lined pages at the end of this book. Write the question number against your answer(s).
- Do all rough work in this book. Cross through any work you do not want to be marked.
- Show all your working.

Information

- The marks for questions are shown in brackets.
- The maximum mark for this paper is 85.
- You are expected to use a scientific calculator where appropriate.
- A Data and Formulae Booklet is provided as a loose insert.

For Examiner's Use	
Question	Mark
1	
2	
3	
4	
5	
6	
7–31	
TOTAL	



Section AAnswer **all** questions in this section.**0 1**

A capacitor of capacitance 63 pF is made from two parallel metal plates separated by an air gap.

The capacitor is charged so that it stores a charge of 7.6×10^{-10} C; it is then isolated.

A sheet of mica of dielectric constant 6.0 is inserted between the plates so that it completely fills the space between them. The mica does not discharge the capacitor and does not change the separation of the plates.

0 1 . 1

Explain what is meant by a dielectric constant of 6.0

[1 mark]

0 1 . 2

Mica is made up of polar molecules. As the mica is inserted, the capacitance of the capacitor changes.

Explain how the polar molecules cause this change in capacitance.

[3 marks]



0 1 . 3

Calculate the difference between the initial energy stored by the capacitor and the energy stored when the mica has been fully inserted.

[3 marks]

energy difference = _____ J

Question 1 continues on the next page**Turn over ►**

Figure 1 shows the structure of a variable capacitor used for measuring angular movement. The capacitor consists of two semicircular metal plates. These plates are parallel and are separated by an air gap.

Figure 1

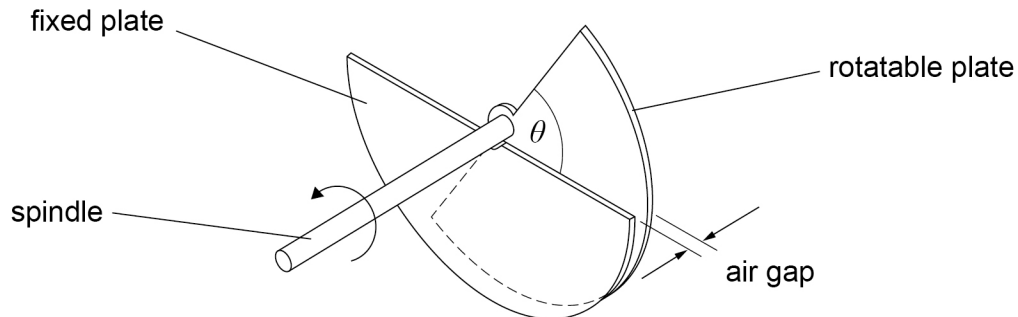

To vary the capacitance, one of the plates is rotated through an angle θ using the spindle. The other plate remains fixed.

0 1 . 4

Sketch a graph on **Figure 2** to show how the capacitance C varies with θ as the spindle is turned through 360° .
When θ is 0° , the plates completely overlap.

[2 marks]

Figure 2

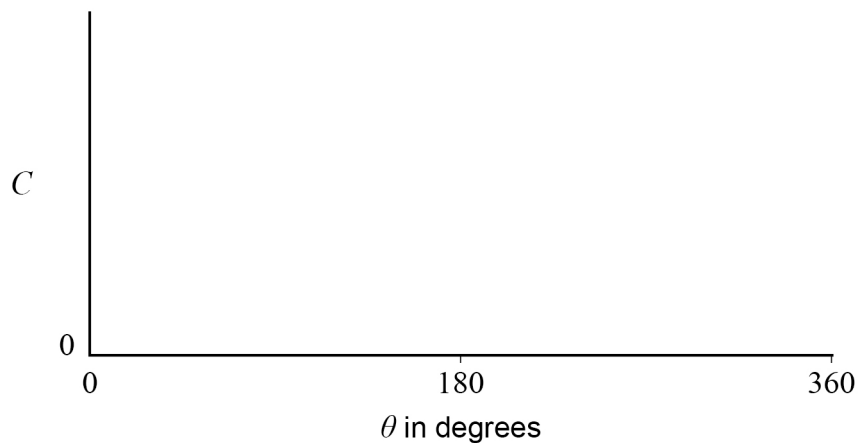

0 1 . 5

In one situation, the variable capacitor is too large for the available space.

The same maximum capacitance is required using plates that have half the diameter of the original capacitor.

Explain, with numerical detail, **two** ways in which this can be achieved.

[3 marks]

1 _____

2 _____

12

Turn over for the next question**Turn over ►**

0 2

The Global Positioning System (GPS) uses satellites to support navigation on Earth.

0 2 . 1

One GPS satellite is in a circular orbit at a height h above the surface of the Earth. The Earth has mass M and radius R .

Show that the angular speed ω of the satellite is given by

$$\omega = \sqrt{\frac{GM}{(R+h)^3}}$$

[2 marks]**0 2 . 2**

Calculate the orbital period of the satellite when h equals 2.02×10^7 m.

[2 marks]

orbital period = _____ s



0 2 . 3

Figure 3 shows the orbital plane of the satellite inclined at an angle to the equator. **X**, **Y** and **Z** are locations on the Earth.

X is at the North Pole, **Y** is on a high mountain and **Z** is on the equator.

Figure 3

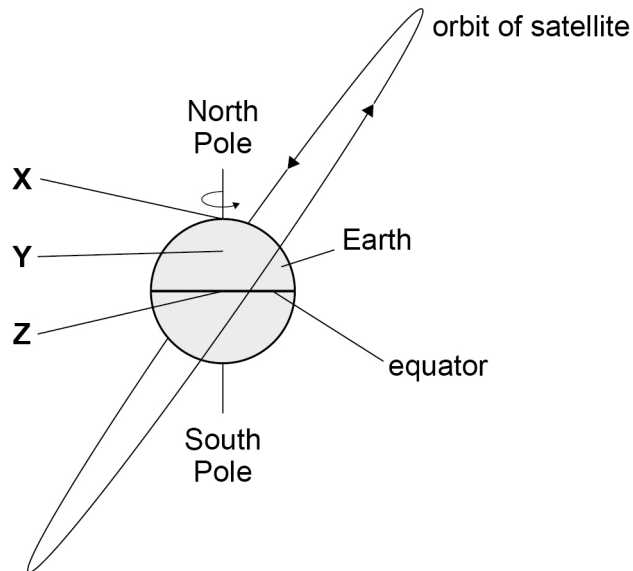

The satellite is to be launched from one of the locations.

State and explain which launch site **X**, **Y** or **Z** minimises the amount of fuel required to send the satellite into its orbit.

[2 marks]

Question 2 continues on the next page

Turn over ►



0 2 . 4

The satellite has a mass of 1630 kg.

Calculate the gravitational potential energy of the satellite when in the orbit in Question 02.2.

[2 marks]

gravitational potential energy = _____ J

0 2 . 5

A different satellite is in a higher circular orbit.

Explain how the linear speed of this satellite compares with the linear speed of the satellite in Question 02.1.

[2 marks]

10



Turn over for the next question

*Do not write
outside the
box*

**DO NOT WRITE ON THIS PAGE
ANSWER IN THE SPACES PROVIDED**

Find Personal Tutor from www.wisesprout.co.uk

找名校导师，用小草线上辅导（微信小程序同名）

Turn over ►



0 3

Figure 4 and **Figure 5** show apparatus used in an experiment to confirm the distribution of atom speeds in a gas at a particular temperature.

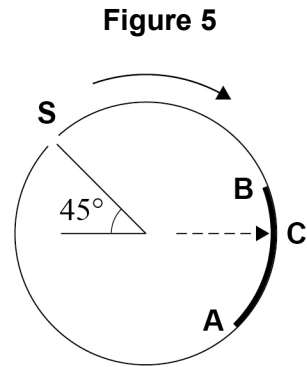
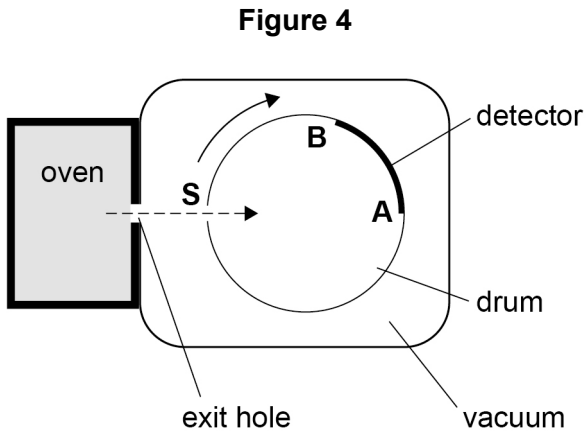

The oven contains an ideal gas kept at a constant temperature. Atoms of the gas emerge from the oven and some pass through the narrow slit **S** in a rapidly rotating drum. The drum is in a vacuum.

0 3 . 1

Explain why the drum must be in a vacuum.

[1 mark]



One atom leaves the oven, enters the drum through **S** and travels in a straight line across the drum.

In the time taken for the atom to move from **S** to the detector **AB**, the drum rotates through 45° . The atom hits the detector at point **C**, as shown in **Figure 5**.

drum diameter = distance from **S** to **A** = 0.500 m
drum rotational speed = 120 revolutions per second

0 3 . 2 Show that the atom is moving at a speed of about 500 m s^{-1} .

[2 marks]

0 3 . 3 The speed of the atom in Question **03.2** is equal to c_{rms} , the root mean square speed of the atoms of the gas in the oven.
The molar mass of the gas is $0.209 \text{ kg mol}^{-1}$.

Calculate the temperature of the gas in the oven.

[3 marks]

temperature = _____ K

Question 3 continues on the next page

Turn over ►



0 3 . 4

The oven temperature is kept constant during the experiment but the pressure in the oven decreases as atoms leave through the exit hole.

Explain, using the kinetic theory, why the pressure decreases.

[2 marks]

0 3 . 5

The pressure of gas in the oven is initially 5.0×10^4 Pa.

The volume of the oven is 2.7×10^{-2} m³.

During the experiment the pressure in the oven decreases to 4.5×10^4 Pa.

Calculate, in mol, the amount of gas that has emerged from the oven.

[1 mark]

amount of gas = _____ mol



0 3 . 6

Atoms enter the drum every time **S** passes the exit hole. The detector darkens at the point where an atom strikes it.

After a time, the detector is removed from the drum.

Figure 6 shows the appearance of the detector.

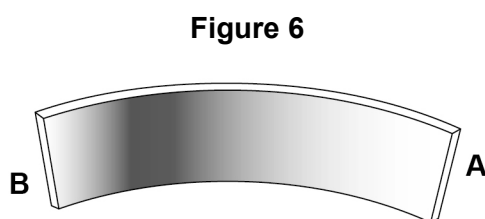

A new detector is placed in the drum and the experiment is repeated with a new sample of the same gas at a higher temperature.

Describe and explain the appearance of this detector when the experiment is repeated.

[2 marks]

Turn over for the next question

Do not write
outside the
box

Find Personal Tutor from www.wisesprout.co.uk

找名校导师，用小程序线上辅导（微信小程序同名）

11

Turn over ►



0 4

Figure 7 shows a search coil positioned on the axis of an electromagnet, with the plane of the search coil perpendicular to the axis. A magnetic field is produced by a constant current in the electromagnet. Assume that the magnetic flux density inside the search coil is uniform.

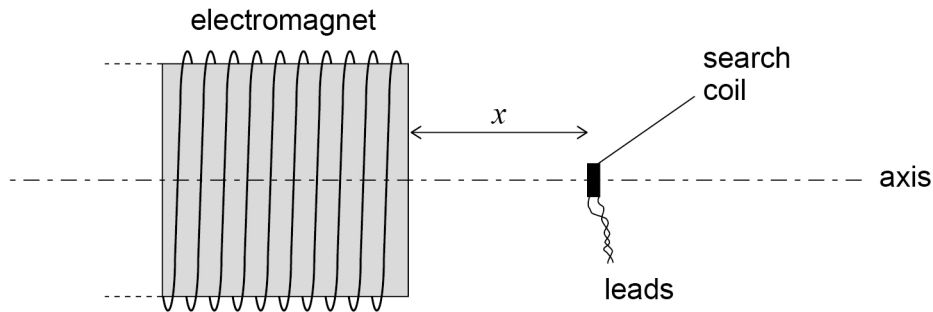
Figure 7

The distance between the search coil and the end of the electromagnet is x . **Figure 8** shows how the magnetic flux density B of the field varies with x .

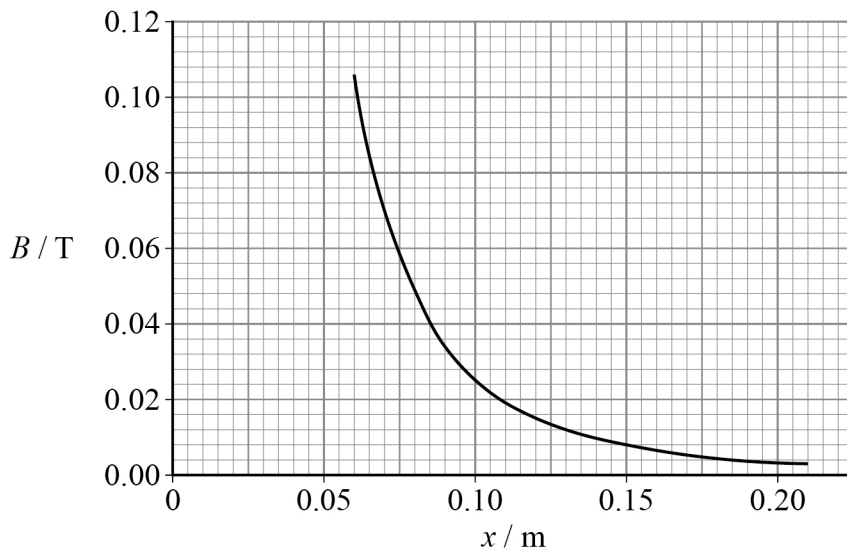
Figure 8

The search coil has 200 turns and a cross-sectional area of $3.5 \times 10^{-5} \text{ m}^2$.

0 4 . 1 The search coil is placed at $x = 0.070 \text{ m}$.

Show that the magnetic flux linkage through the search coil is about $5 \times 10^{-4} \text{ Wb}$.

[2 marks]

Question 4 continues on the next page

Turn over ►



The search coil is now moved at a constant speed of 0.80 m s^{-1} along the axis so that x is increasing. An emf is induced across the terminals of the search coil.

0 4 . 2

Explain what happens to the value of the emf as the search coil moves.

[2 marks]

0 4 . 3

The search coil passes through the position where $x = 0.10 \text{ m}$.

Deduce whether the emf can exceed 5 mV for values of x greater than 0.10 m .

[4 marks]



0 5

Figure 9 shows a cyclotron. A proton is released from rest and is accelerated each time it reaches the gap between two horizontal 'dees' D_1 and D_2 . Between these accelerations the proton moves at constant speed. A vertical magnetic field of flux density B acts over the dees so that the proton follows a semicircular path in each dee.

The dees are connected to an alternating potential difference (pd). This pd is adjusted so that the proton is always accelerated by the peak electric field as it crosses the gap between the dees.

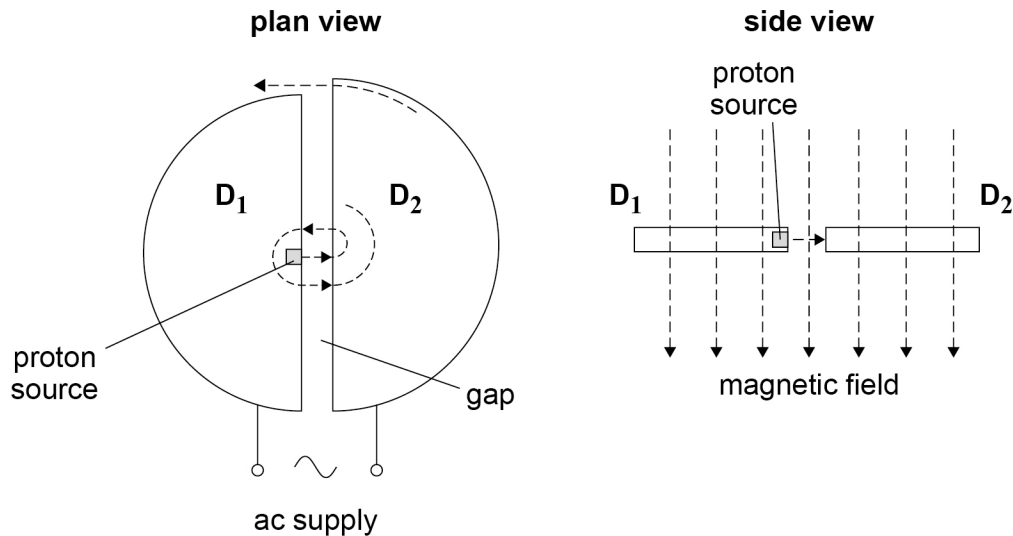
Figure 9

0 5 . 1

Explain why the proton travels in a semicircular path in a dee.

[2 marks]

Question 5 continues on the next page

Turn over ►



0 5 . 2

The peak pd of the alternating supply is 10.0 kV. The proton leaves the cyclotron with kinetic energy of 14 MeV.

Determine the number of times the proton moves across the gap before it leaves the cyclotron.

[1 mark]

number of times = _____

The radius of the outermost semicircular path of the proton is R and the proton leaves with a maximum kinetic energy E_k .

0 5 . 3

Show that E_k is given by

$$E_k = \frac{e^2 B^2 R^2}{2m_p}$$

[3 marks]

0 5 . 4

A hospital decides to purchase a cyclotron in order to manufacture its own radioactive isotopes using high-speed protons.

The required minimum kinetic energy of the emerging protons is 11 MeV.

The cost of a cyclotron is approximately proportional to $E_k^{1.5}$.

The cost of a 10 MeV cyclotron is about £2.3 million.

Table 1 gives information for three cyclotrons **X**, **Y** and **Z**.

Table 1

Cyclotron	B / T	R / m
X	1.3	0.38
Y	1.1	0.50
Z	0.5	0.60

Deduce which cyclotron **X**, **Y** or **Z** will satisfy the energy requirement for the lowest cost.

Go on to determine the approximate cost of this cyclotron.

[4 marks]

cyclotron = _____

cost = _____

10

Turn over ►



06.1

Explain, in terms of binding energy, why energy can be released when two nuclei undergo nuclear fusion.

[2 marks]

06.2

During the collapse of a supermassive star, helium-3 and oxygen-17 fuse to release energy. The equation for this reaction is

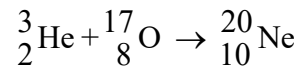

Table 2 gives data for these nuclei.

Table 2

Nucleus	Mass / u
${}^3_2\text{He}$	3.01603
${}^{17}_8\text{O}$	16.99913
${}^{20}_{10}\text{Ne}$	19.99244

Calculate, in J, the energy released when this reaction occurs.

[2 marks]

energy released = _____ J



0 6 . 3

One model of nuclear fusion suggests that fusion happens when nuclei touch.

Initially the helium nucleus and oxygen nucleus are separated so that the force between them is negligible. They move towards each other until they fuse. Fusion occurs when their centres are separated by a distance of 5.1×10^{-15} m.

Figure 10 shows the initial positions and final positions of the nuclei.

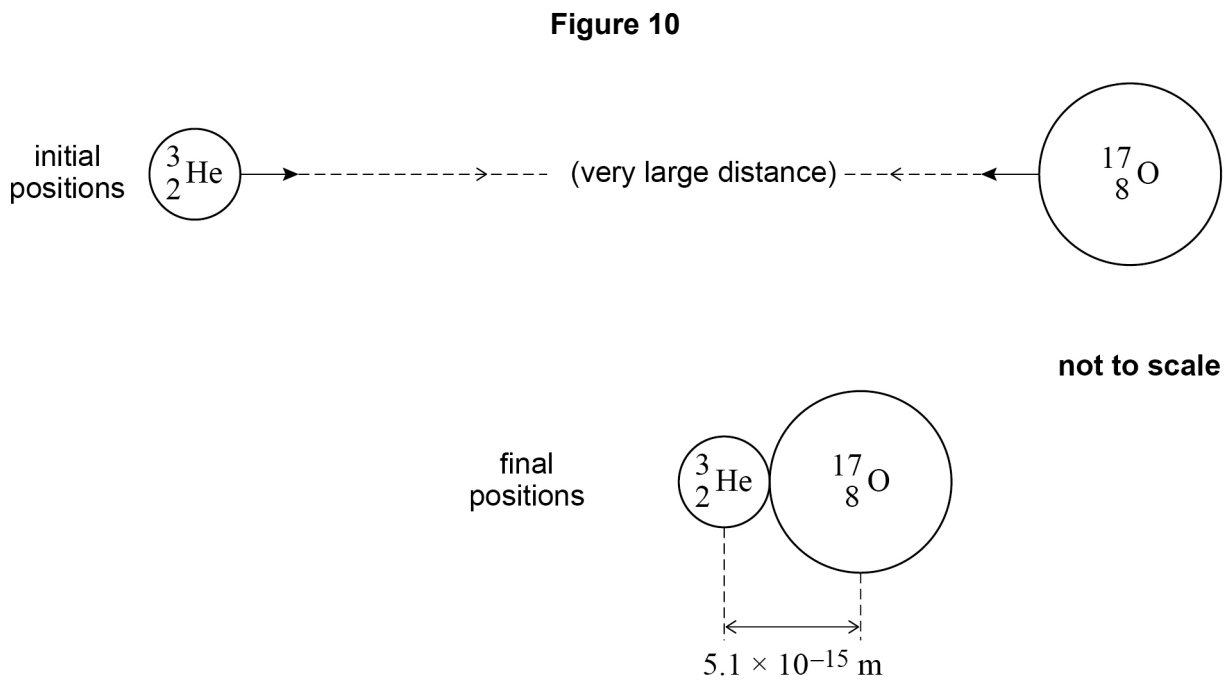

Calculate the total change in electrostatic potential energy between the initial positions and final positions of the nuclei.

[2 marks]

change in electrostatic potential energy = _____ J

Question 6 continues on the next page

Turn over ►



Section B

Each of Questions **07** to **31** is followed by four responses, **A**, **B**, **C** and **D**.

For each question select the best response.

Only **one** answer per question is allowed.

For each question, completely fill in the circle alongside the appropriate answer.

CORRECT METHOD WRONG METHODS

If you want to change your answer you must cross out your original answer as shown.

If you wish to return to an answer previously crossed out, ring the answer you now wish to select as shown.

You may do your working in the blank space around each question but this will not be marked.
Do **not** use additional sheets for this working.

07 A solar panel transfers energy at a rate of 1.2 kW to liquid passing through it. The liquid has a specific heat capacity of $4.0 \text{ kJ kg}^{-1} \text{ K}^{-1}$.

When the liquid flows through the solar panel, its temperature increases by 3.0 K.

The flow rate of the liquid is

[1 mark]

- A** 0.10 kg s^{-1} .
- B** 1.1 kg s^{-1} .
- C** 10 kg s^{-1} .
- D** 100 kg s^{-1} .

Turn over ►



0 8

A gas occupies a volume V . Its particles have a root mean square speed (c_{rms}) of u . The gas is compressed at constant temperature to a volume $0.5V$.

What is the root mean square speed of the gas particles after compression?

[1 mark]

A $\frac{u}{2}$

B u

C $2u$

D $4u$

0 9

A fixed mass of gas is heated at constant volume. The graph is drawn for this process.

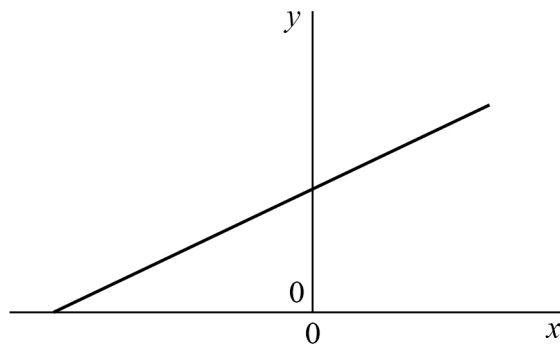

What do x and y represent?

[1 mark]

	x	y	
A	pressure in Pa	temperature in $^{\circ}\text{C}$	<input type="checkbox"/>
B	temperature in $^{\circ}\text{C}$	pressure in Pa	<input type="checkbox"/>
C	pressure in Pa	temperature in K	<input type="checkbox"/>
D	temperature in K	pressure in Pa	<input type="checkbox"/>



1 0

Three particles are travelling in the same plane with velocities as shown in the vector diagram.

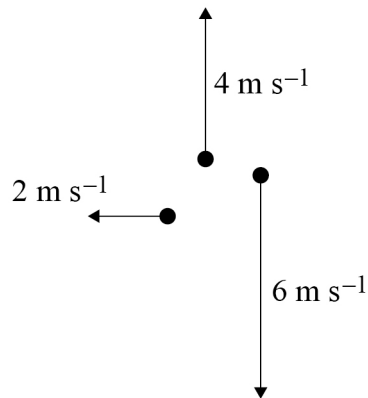

What is the root mean square speed of the particles?

[1 mark]

A 4.3 m s^{-1}

B 7.5 m s^{-1}

C 19 m s^{-1}

D 56 m s^{-1}

Turn over for the next question

Turn over ►



1 1

The diagram shows gravitational equipotentials. Adjacent equipotentials are separated by an equal gravitational potential difference V .

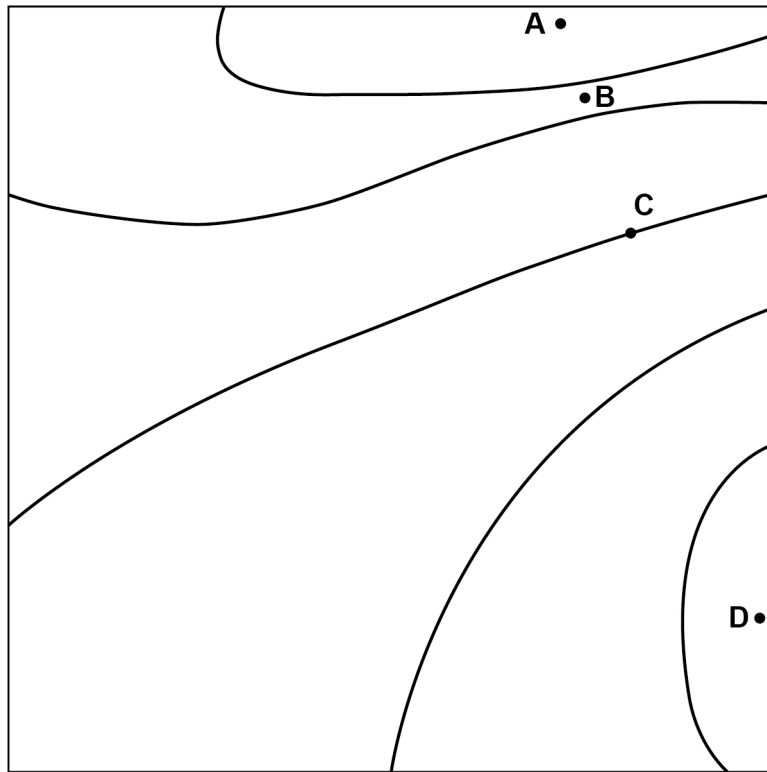

Which point has the greatest gravitational field strength?

[1 mark]

- A
- B
- C
- D



1 2

A planet has radius R and density ρ . The gravitational field strength at the surface is g .

What is the gravitational field strength at the surface of a planet of radius $2R$ and density 2ρ ?

[1 mark]

- A** $2g$
- B** $4g$
- C** $8g$
- D** $16g$

1 3

The diagram shows equipotential lines for a uniform gravitational field. The lines are separated by 20 m.

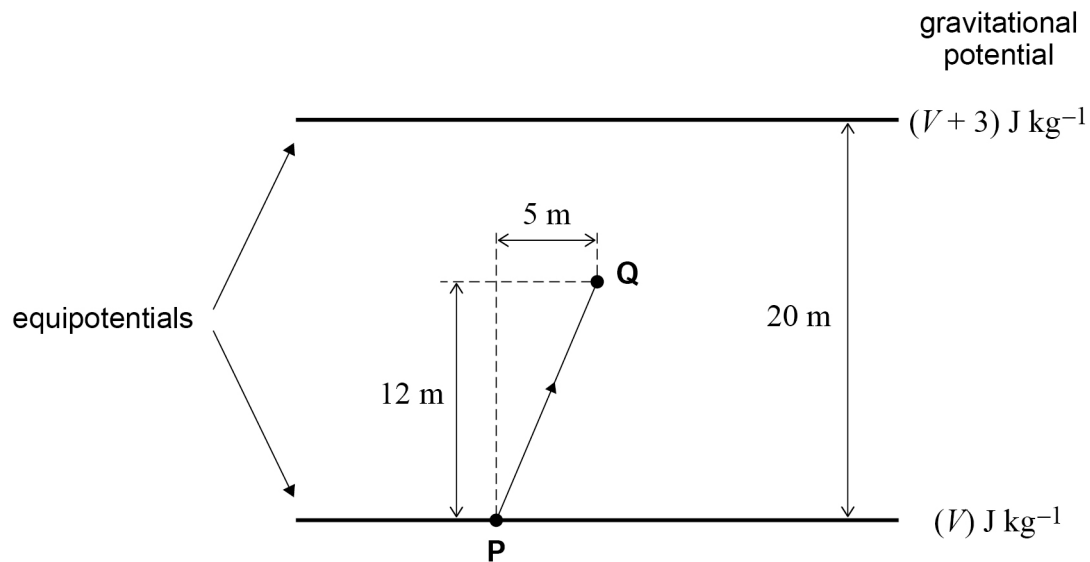

An object of mass 4 kg is moved from **P** to **Q**.

What is the work done against gravity to move the object?

[1 mark]

- A** 7.2 J
- B** 7.8 J
- C** 10.2 J
- D** 36 J

Turn over ►

1 4

The diagram shows a particle with charge $+Q$ and a particle with charge $-Q$ separated by a distance d .

The particles exert a force F on each other.

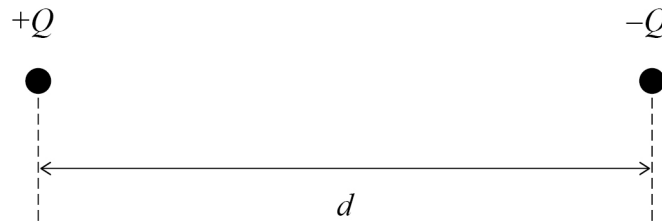

An additional charge of $+2Q$ is then given to each particle and their separation is increased to $2d$.

What is the force that now acts between the particles?

[1 mark]

- A** an attractive force of $\frac{9}{2}F$
- B** an attractive force of $\frac{9}{4}F$
- C** a repulsive force of $\frac{3}{2}F$
- D** a repulsive force of $\frac{3}{4}F$

1 5

Two protons are separated by distance r .

The electrostatic force between the two protons is X times the gravitational force between them.

What is the best estimate for X ?

[1 mark]

- A** 10^{20}
- B** 10^{28}
- C** 10^{36}
- D** 10^{42}



1 6

Two parallel metal plates separated by a distance d have a potential difference V across them. A particle with charge Q is placed midway between the plates.

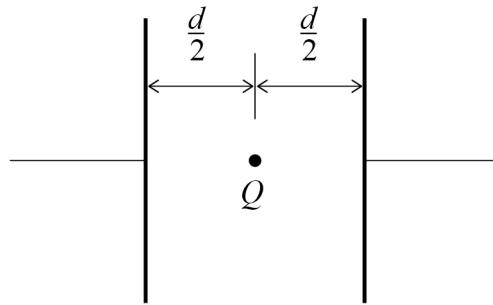

What is the magnitude of the electrostatic force acting on the particle?

[1 mark]

A zero

B $\frac{QV}{2d}$

C $\frac{QV}{d}$

D $\frac{2QV}{d}$

1 7

Two charged particles **P** and **Q** are separated by a distance of 120 mm. **X** is a point on the line between **P** and **Q** where the electric potential is zero.

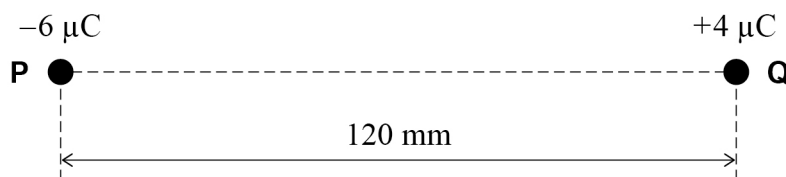

What is the distance from **P** to **X**?

[1 mark]

A 40 mm

B 48 mm

C 60 mm

D 72 mm

Turn over ►



1 8

An isolated spherical conductor is charged.
The conductor has a radius R and an electric potential V . The electric field strength at its surface is E .

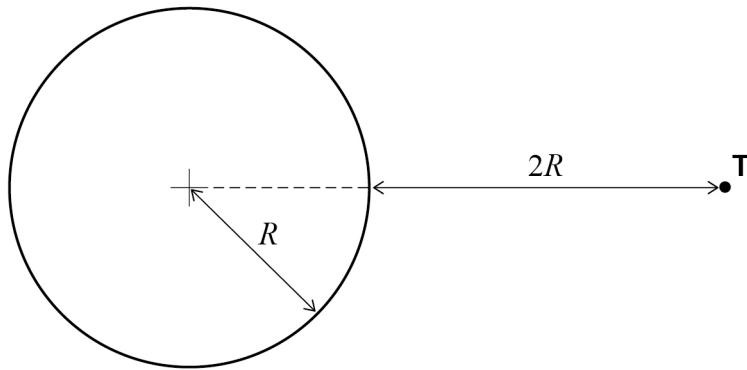

Point **T** is a distance $2R$ from the surface.

What are the electric field strength and electric potential at **T**?

[1 mark]

	Electric field strength	Electric potential	
A	$\frac{E}{2}$	$\frac{V}{4}$	<input type="checkbox"/>
B	$\frac{E}{3}$	$\frac{V}{9}$	<input type="checkbox"/>
C	$\frac{E}{4}$	$\frac{V}{2}$	<input type="checkbox"/>
D	$\frac{E}{9}$	$\frac{V}{3}$	<input type="checkbox"/>



1 9

O is the centre of a negatively charged sphere.

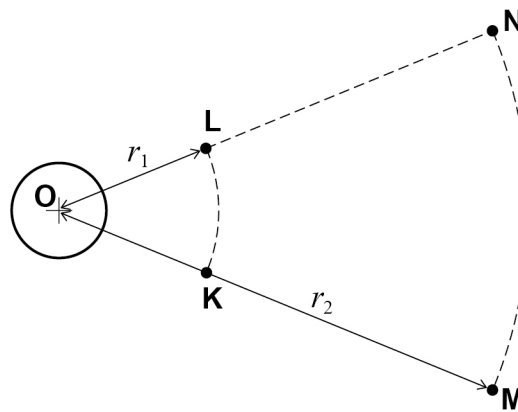

K and **L** are two points at a distance r_1 from **O**.

M and **N** are two points at a distance r_2 from **O**.

Which statement is true?

[1 mark]

- A** The work done moving an electron from **M** to **K** is the same as that done moving an electron from **K** to **L**.
- B** The work done moving a positron from **K** to **M** is the same as that done moving an electron from **K** to **M**.
- C** No work is done moving an electron from **M** to **N**.
- D** No work is done moving a positron from **L** to **N**.

Turn over for the next question

Turn over ►



2 0

The capacitor in the circuit is initially uncharged.
The switch is closed at time $t = 0$

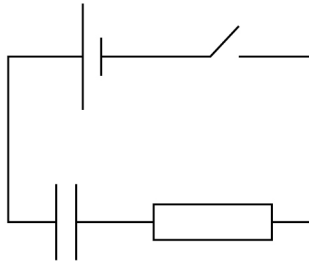

Which pair of graphs shows how the potential difference V across the capacitor and the current I in the circuit change with time t ?

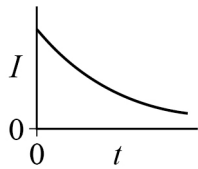
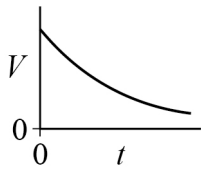
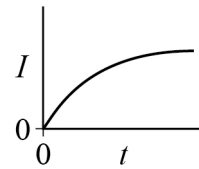
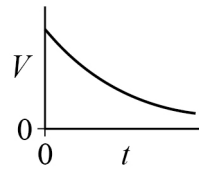
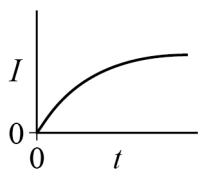
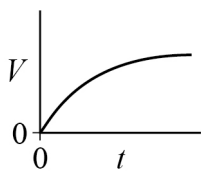
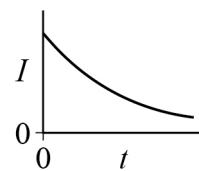
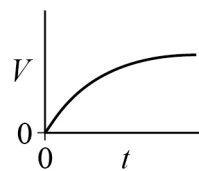
[1 mark]**A****B****C****D****A****B****C****D**

2 1

A short copper rod **R** is placed on a pair of thick horizontal parallel copper rails. A horizontal magnetic field exists in the direction shown by the dashed arrows. The diagram shows the apparatus when viewed from directly above.

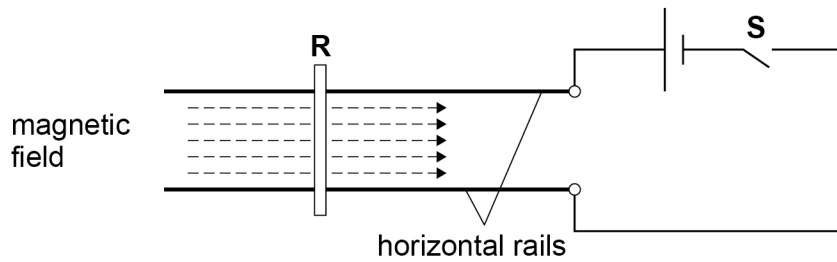

When switch **S** is closed, **R** will tend to

[1 mark]

- A** lift upwards away from the rails.
- B** move to the left.
- C** move to the right.
- D** be pressed downwards onto the rails.

Turn over for the next question

Turn over ►



2 2

The diagram shows a square coil with its plane parallel to a uniform magnetic field.

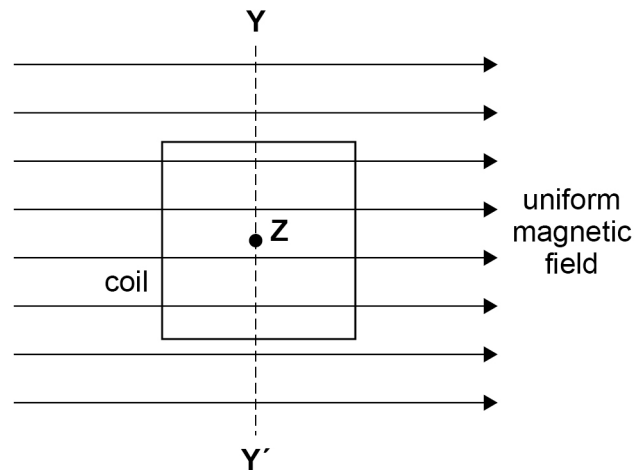

The coil always remains within the magnetic field.
There are four possible changes to the position of the coil:

- moving it to the left
- moving it towards Y
- rotating it about the axis YY'
- rotating it about an axis Z that is at its centre and perpendicular to the plane of the coil.

How many of these changes will result in an induced emf in the coil while the change occurs?

[1 mark]

- A** one
- B** two
- C** three
- D** four

2 3

Mains electricity is rated 230 V in the UK.

Which is correct?

[1 mark]

- A** The mean voltage is 163 V.
- B** The peak voltage is 230 V.
- C** The root mean square voltage is 325 V.
- D** The peak-to-peak voltage is 650 V.



2 4

In a resistor of resistance R , a steady current I dissipates a power P .

In a resistor of resistance $\frac{R}{2}$ there is an alternating current of root mean square value $3I$.

What is the mean power dissipated in the resistor of resistance $\frac{R}{2}$?

[1 mark]

A $9P$

B $\frac{9}{2}P$

C $\frac{9}{4}P$

D $\frac{3}{2}P$

2 5

The primary winding of a transformer has 200 turns and the secondary winding has 1600 turns.

A root mean square (rms) alternating voltage of 25 V is applied to the primary winding causing a primary rms current of 4.0 A. The transformer is 90% efficient.

What are the rms values of the secondary voltage and the secondary current?

[1 mark]

	Secondary voltage / V	Secondary current / A	
A	200	0.50	<input type="checkbox"/>
B	200	0.45	<input type="checkbox"/>
C	180	0.50	<input type="checkbox"/>
D	3.1	29.0	<input type="checkbox"/>

Turn over ►

2 | 6

The diagram shows the path of a proton being deflected by the nucleus of an atom. Point **P** is the position of the proton when it is closest to the nucleus.

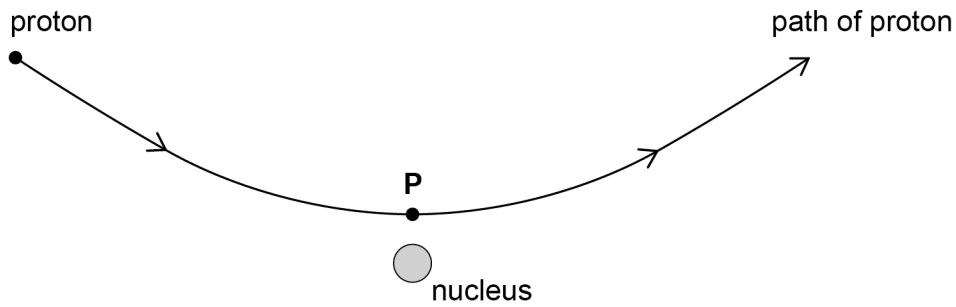

What is **not** true about the proton along its path at **P**?

[1 mark]

- A** Its rate of change of momentum is at a minimum.
- B** Its kinetic energy is at a minimum.
- C** Its potential energy is at a maximum.
- D** Its acceleration is at a maximum.

2 | 7

The diagram shows an area of 0.10 m^2 normal to a line connecting it to a point source of gamma radiation. The source emits photons uniformly in all directions. The area and the source are separated by a distance of 2.0 m .

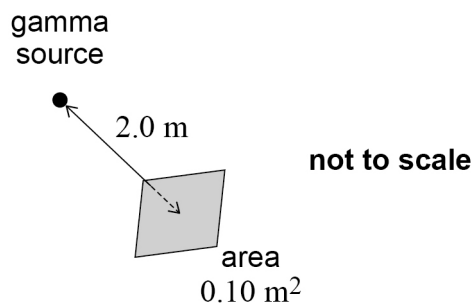

The source emits 5000 gamma photons per second.

How many photons pass through the area every second?

[1 mark]

- A** 500
- B** 250
- C** 10
- D** 2.5



2 8

X and **Y** are two radioactive nuclides. **X** has a half-life of 3.0 minutes and **Y** has a half-life of 9.0 minutes.

Two freshly prepared samples of **X** and **Y** start decaying at the same time. After 18 minutes the number of radioactive nuclei in both samples is the same. The sample of **Y** initially contained N radioactive nuclei.

What was the initial number of radioactive nuclei in the sample of **X**?

[1 mark]

A $4N$

B $16N$

C $32N$

D $64N$

2 9

What is the main purpose of a moderator in a thermal nuclear reactor?

[1 mark]

A to shield the surroundings from ionising radiations

B to decrease the number of fission chain reactions

C to decrease neutron speeds

D to prevent the core from overheating

3 0

In the core of a nuclear reactor, the mass of fuel decreases at a rate of $9.0 \times 10^{-6} \text{ kg hour}^{-1}$ due to nuclear reactions.

What is the maximum power output of the reactor?

[1 mark]

A $2.3 \times 10^8 \text{ W}$

B $1.4 \times 10^{11} \text{ W}$

C $8.1 \times 10^{11} \text{ W}$

D $2.9 \times 10^{15} \text{ W}$

Turn over for the next question

Turn over ►



3 1

${}_{12}^{27}\text{Mg}$ can decay by beta minus emission to one of two possible excited states of ${}_{13}^{27}\text{Al}$.

Both excited states decay by the emission of a gamma photon directly to the ground state.

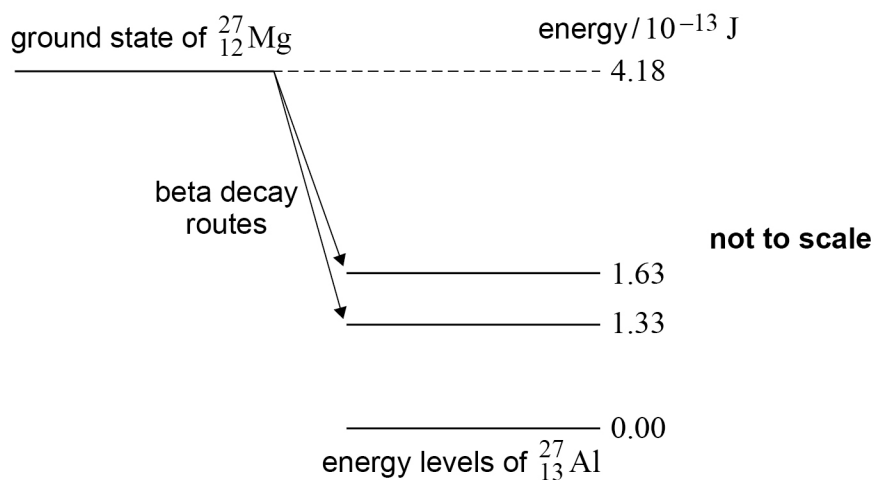

The diagram shows the energy levels and two routes for the beta decay.

One route results in the emission of a gamma photon with a higher frequency than the other photon.

What is the maximum possible kinetic energy for the beta particle emitted in this route?

[1 mark]

- A 1.33×10^{-13} J
- B 1.63×10^{-13} J
- C 2.55×10^{-13} J
- D 2.85×10^{-13} J

END OF QUESTIONS



There are no questions printed on this page

*Do not write
outside the
box*

**DO NOT WRITE ON THIS PAGE
ANSWER IN THE SPACES PROVIDED**

Find Personal Tutor from www.wisesprout.co.uk

找名校导师，用小草线上辅导（微信小程序同名）



There are no questions printed on this page

*Do not write
outside the
box*

**DO NOT WRITE ON THIS PAGE
ANSWER IN THE SPACES PROVIDED**

Find Personal Tutor from www.wisesprout.co.uk

找名校导师，用小草线上辅导（微信小程序同名）

Copyright information

For confidentiality purposes, all acknowledgements of third-party copyright material are published in a separate booklet. This booklet is published after each live examination series and is available for free download from www.aqa.org.uk.

Permission to reproduce all copyright material has been applied for. In some cases, efforts to contact copyright-holders may have been unsuccessful and AQA will be happy to rectify any omissions of acknowledgements. If you have any queries please contact the Copyright Team.

Copyright © 2021 AQA and its licensors. All rights reserved.

